

LTE4T

Pin clamp with vanishing hook

L	T	E	4	T	2	1	0	1	0	-	-
1		2		3	4	5	6	7		8	

1 Series	2 Size	3 Model
-----------------	---------------	----------------

LTE = Pin clamp with vanishing hook

4

T = Refer to enclosed technical drawings

4 Pin diameter	5 Pin	6 Working height
-----------------------	--------------	-------------------------

2 = Ø 20 mm
 3 = Ø 25 mm
 4 = Ø 30 mm
 5 = Ø 35 mm
 6 = Ø 40 mm
 Different diameters upon request

0 = No
 1 = With pin

0 = Standard

7 Control module	8 Progressive numbering
-------------------------	--------------------------------

10 = 1 connector - standard software
 20 = 2 connectors - standard software

Progressive numbers for special products assigned by Sales Dept.

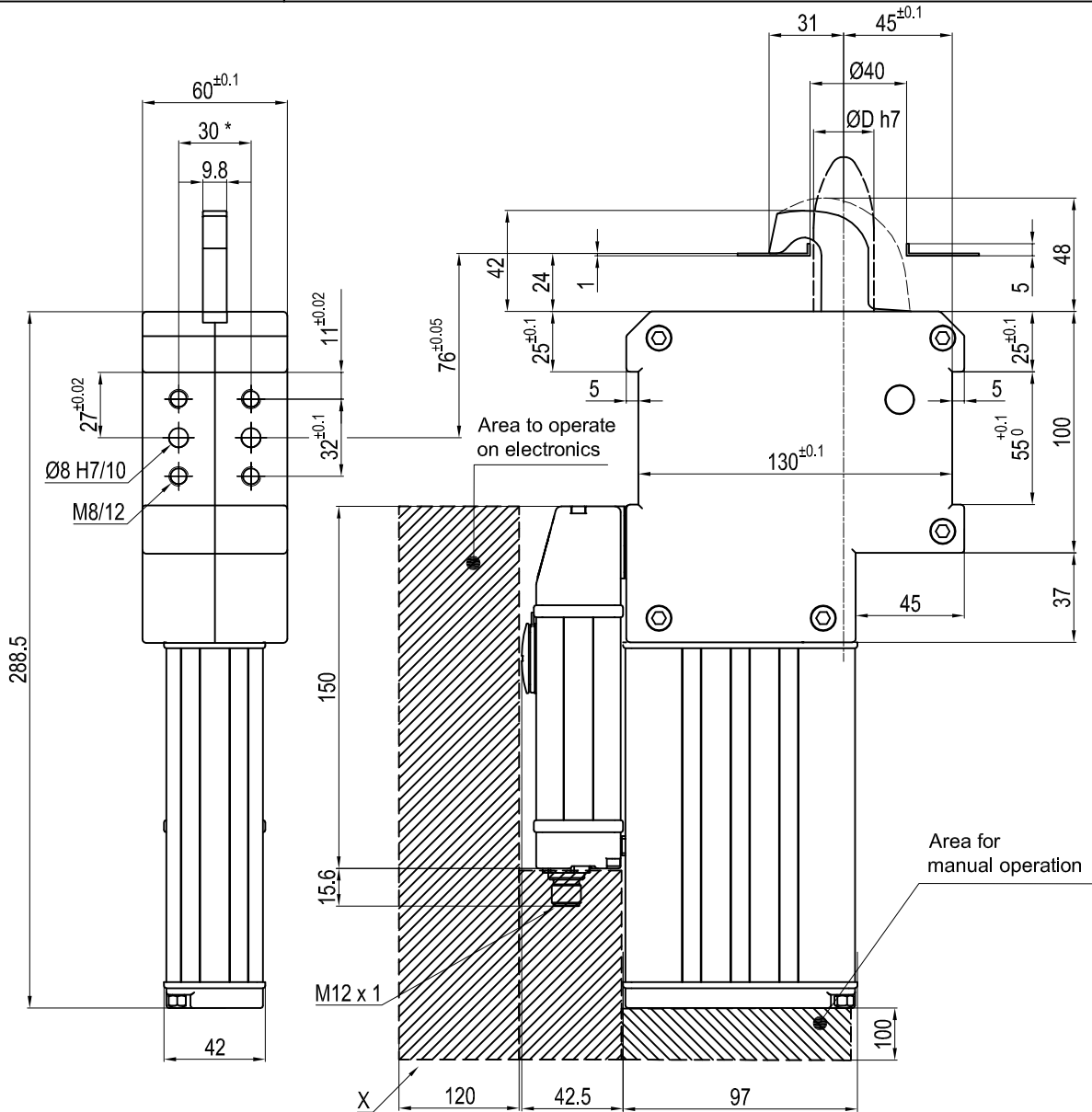

*: TOLERANCE FOR DOWEL HOLES ± 0.02
FOR SCREW HOLES ± 0.1

Ordering code

LTE 4 T _ 0 0

Progressive number
Module
Working height
Pin
Pin diameter
Version
Size
Type

ØD	20	25	30	35	40
----	----	----	----	----	----

Temperature range : 5° + 40° C
Class protection : IP 65

Size	Clamping Force	Weight
4	350daN	4.1 Kg.

Subject to technical modifications without notice

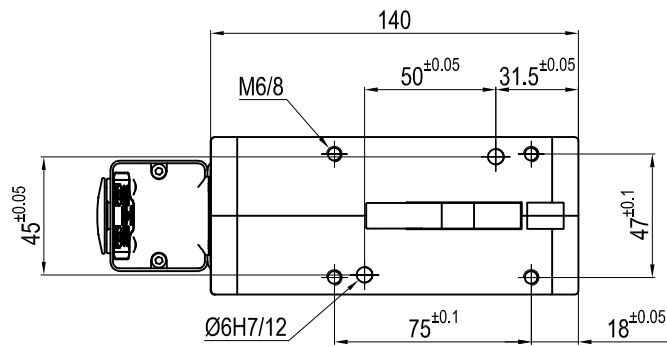

SEEN BY X

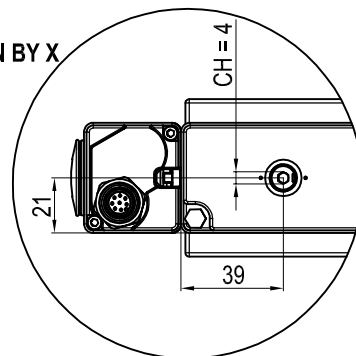

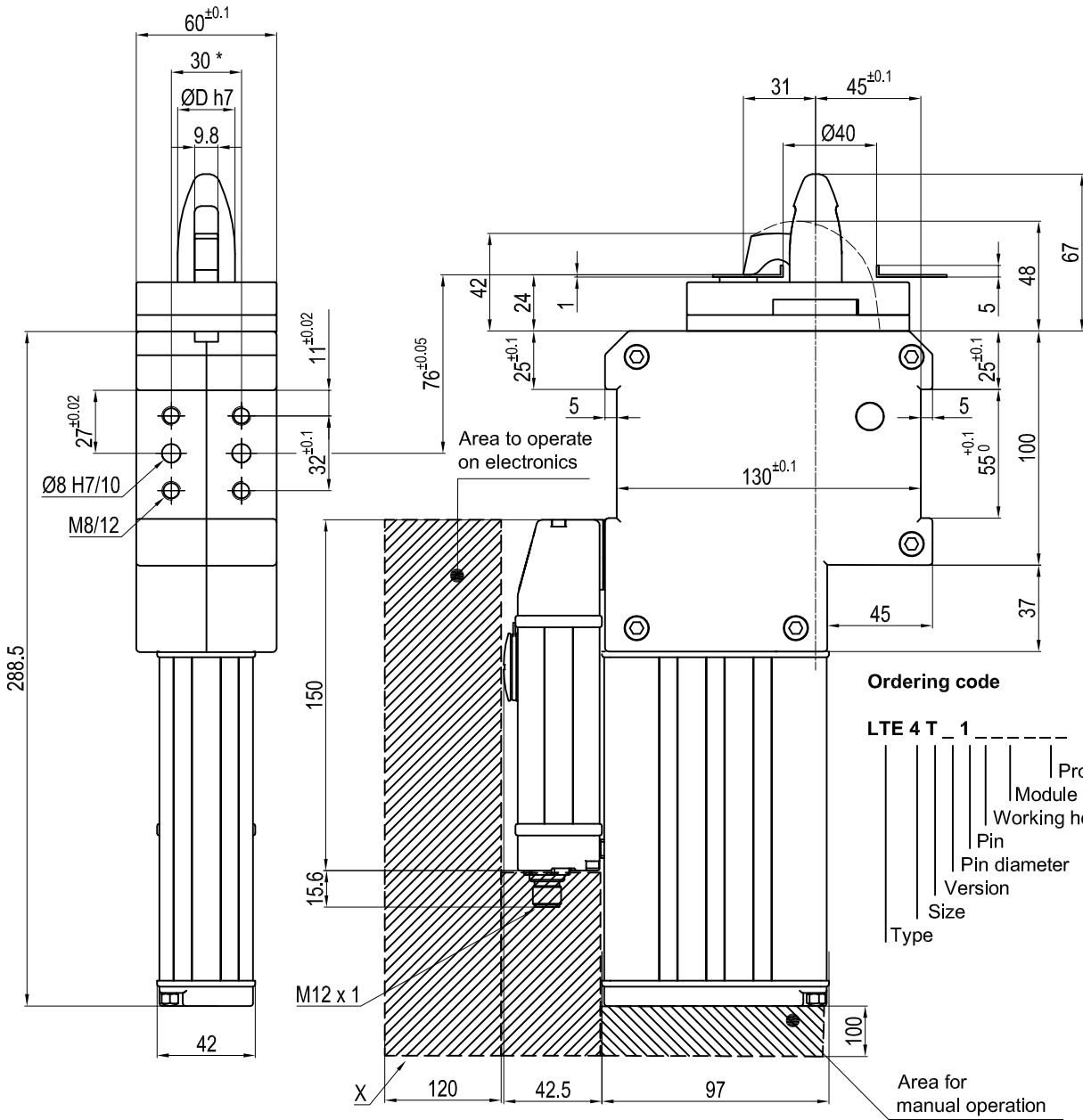

* : TOLERANCE FOR DOWEL HOLES ± 0.02
FOR SCREW HOLES ± 0.1

ØD	20	25	30	35	40
----	----	----	----	----	----

Temperature range : 5° ÷ 40° C
Class protection : IP 65

Size	Clamping Force	Weight
4	350daN	4.1 Kg.

Subject to technical modifications without notice

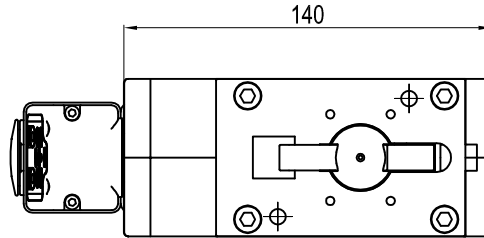

SEEN BY X

